

**NOTE**

All numerical values are in metric units [with U.S. customary units in brackets]. Dimensions are in millimeters [and inches]. Unless otherwise specified, dimensions have a tolerance of  $\pm 0.13$  [.005] and angles have a tolerance of  $\pm 2^\circ$ .

## 1. INTRODUCTION

This specification covers the requirements for application of AMP\* AMPLIMITE HD-20 Straight Solder Contact Tine, Front Metal Shell Plug and Receptacle Connectors for printed circuit (pc) board and panel mounting applications. They are available with 9, 15, 25, 37, and 50 positions, and various types of integral hardware, including threaded inserts, retention inserts, and fixed female screwlocks. They are also available with standard mounting holes that will accept removable screwlocks or commercially available hardware. The connectors are designed to be placed on the pc board manually.

Figure 1 provides terminology for connector features that will be used throughout this specification. Use of these terms will facilitate assistance when corresponding with AMP Representatives.

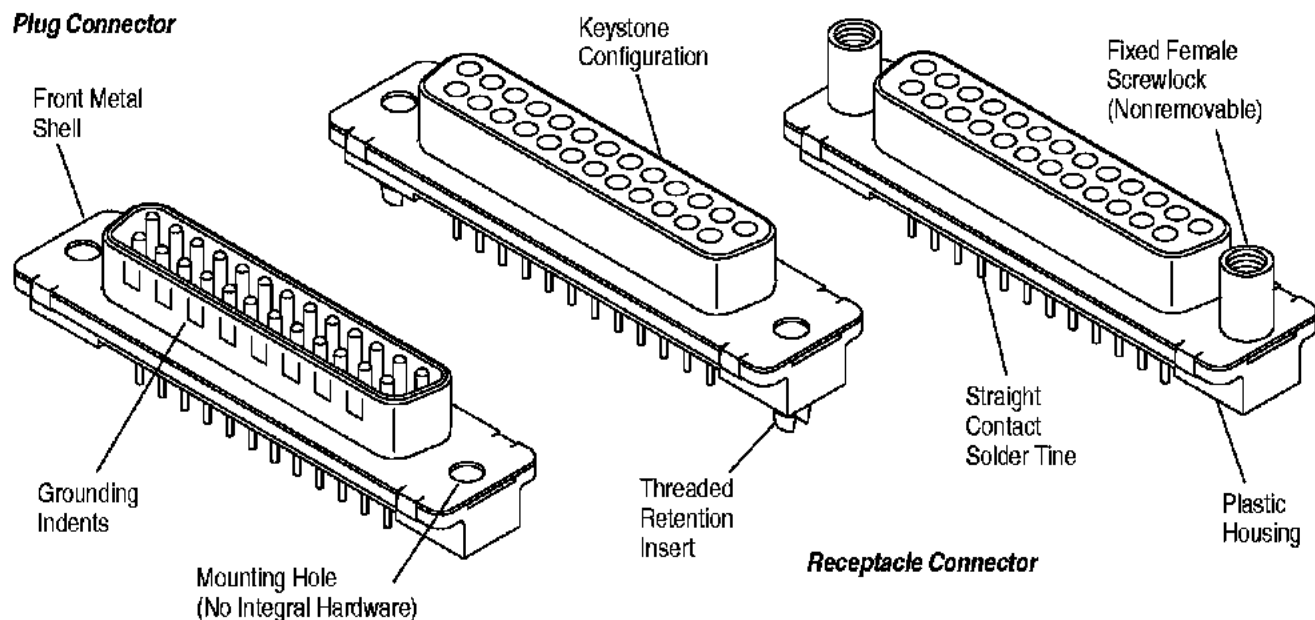

Figure 1

## 2. REFERENCE MATERIAL

### 2.1. Revision Summary

This paragraph is reserved for revision summary of changes and additions made to this specification. The following changes and additions were made for this revision.

Per EC 0990-0707-98:

- Added torque values in Paragraph 3.7
- Expanded soldering Information in Paragraph 3.8

### 2.2. Customer Assistance

Reference Part Number 745968 and Product Code 7418 are representative numbers of AMPLIMITE HD-20 Straight Contact Tine, Front Metal Shell Connectors. Use of these numbers will identify the product line and expedite your inquiries through an AMP service network established to help you obtain product and tooling information. Such information can be obtained through a local AMP Representative (Sales Engineer, Applications Engineer, etc.) or, after purchase, by calling the Tooling Assistance Center or AMP FAX number at the bottom of page 1.

**2.3. Drawings**

Customer Drawings for specific products are available from the responsible AMP Engineering department. The information on Customer Drawings takes priority if there is a conflict with this specification or with any other technical documentation supplied by AMP Incorporated.

**2.4. Product Specification**

See AMP Product Specification 108-40025 for performance requirements, test data, and limitations that may apply to the connectors.

**2.5. Bulletins**

AMP Corporate Bulletin 401-52 is available upon request and can be used as a guide in soldering. This bulletin provides information on various flux types and characteristics along with the commercial designation and flux removal procedures. A checklist is attached to the bulletin as a guide for information on soldering problems.

**3. REQUIREMENTS**

**3.1. Storage**

**A. Ultraviolet Light**

Prolonged exposure to ultraviolet light may deteriorate the chemical composition used in connectors.

**B. Shelf Life**

The connectors should remain in the shipping containers until ready for use to prevent damage. They should be used on a first in, first out basis to avoid storage contamination that could adversely affect signal transmissions.

**C. Chemical Exposure**

Do not store connectors near any chemicals listed below, as they may cause stress corrosion cracking in the components.

Do not store modular jacks near any chemicals listed below, as they may cause stress corrosion cracking in the components.

Alkalies	Ammonia	Citrates	Phosphates	Citrates	Sulfur Compounds
Amines	Carbonates	Nitrites	Sulfur Nitrites		Tartrates

**3.2. Mating**

To ensure full mating of the connectors, the length between the mated connectors must be considered when determining the method of mounting and the panel thickness when the connector is to be mounted to it. This dimension is shown in Figure 2.

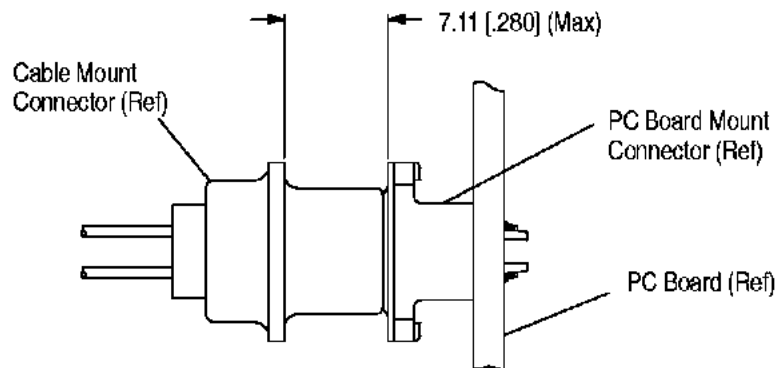

Figure 2

**3.3. Connector Shell Sizes**

There are five industry standard shell sizes available for these connectors. A composite of the five sizes with the overall dimension for each is provided in Figure 3.

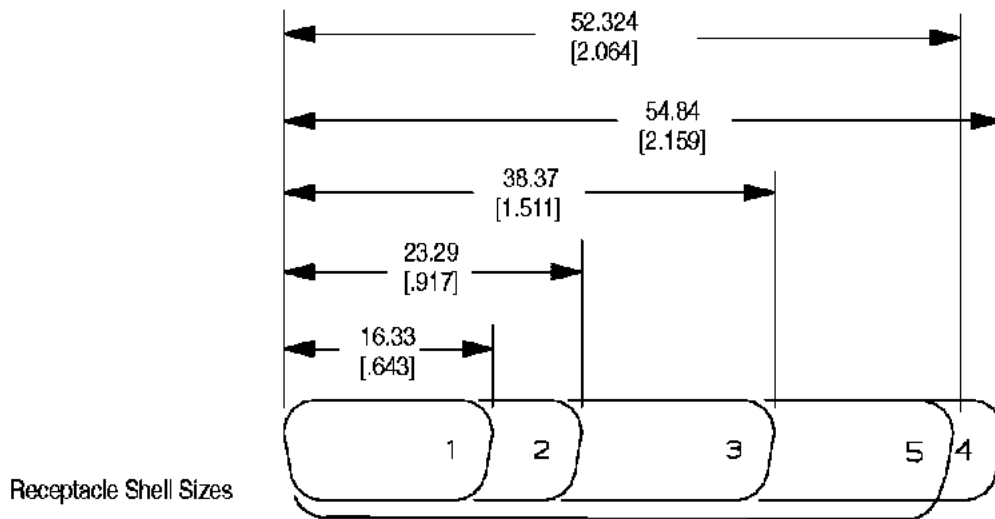

Figure 3

**3.4. Printed Circuit Board**

**A. Thickness**

The connectors are designed for pc boards up to 3.18 [.125] thick. Those with post lengths of 3.18 [.125] are recommended for pc boards up to 2.36 [.093] thick. Those with post lengths of 4.32 [.170] are recommended for pc boards up to 3.18 [.125] thick.

**B. Layout Patterns**

The connectors are placed on the pc board manually. Care should be taken to prevent deformation of the contact solder tines *prior* to insertion into the pc board. It is important to note that the contact solder tines require precise hole dimensions. The pc board holes must be drilled and plated-through to the dimensions provided in Figure 4.

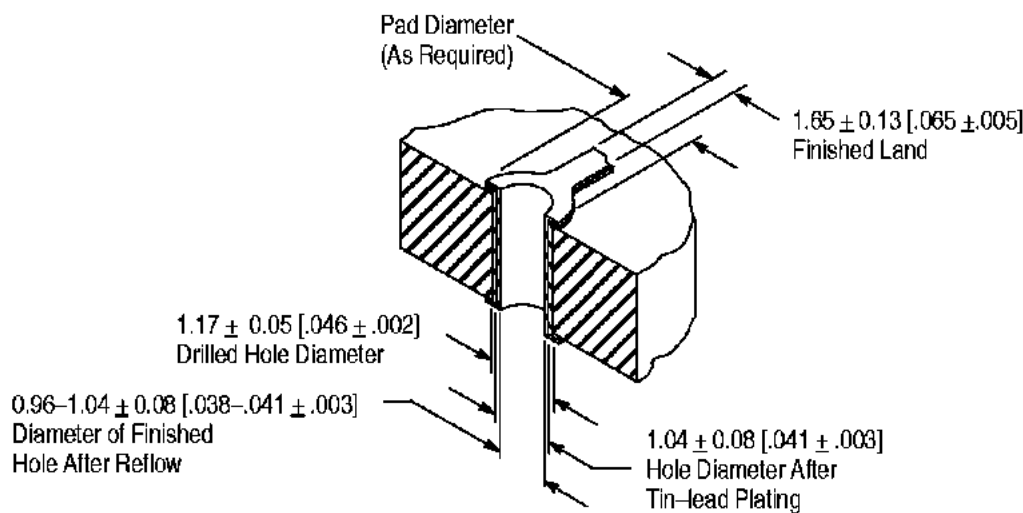

PC board layout patterns for each connector shell size are provided in Figure 5.

**Plug and Receptacle Layouts  
(Recommended PC Board Mounting Dimensions)  
(Connector Side of Board)**

*Size 1 (9-Position)*

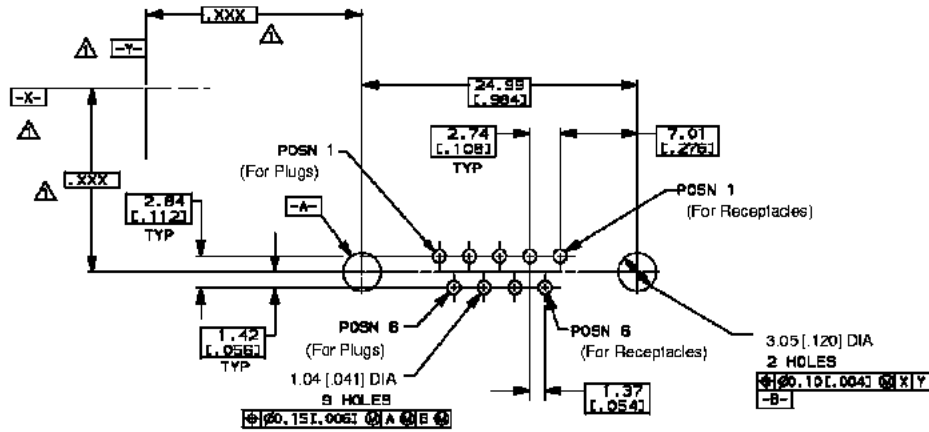

*Size 2 (15-Position)*

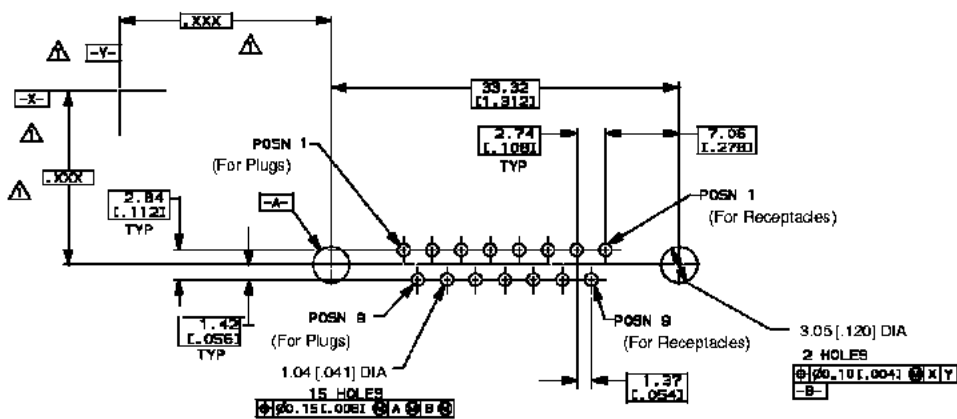

*Size 3 (25-Position)*

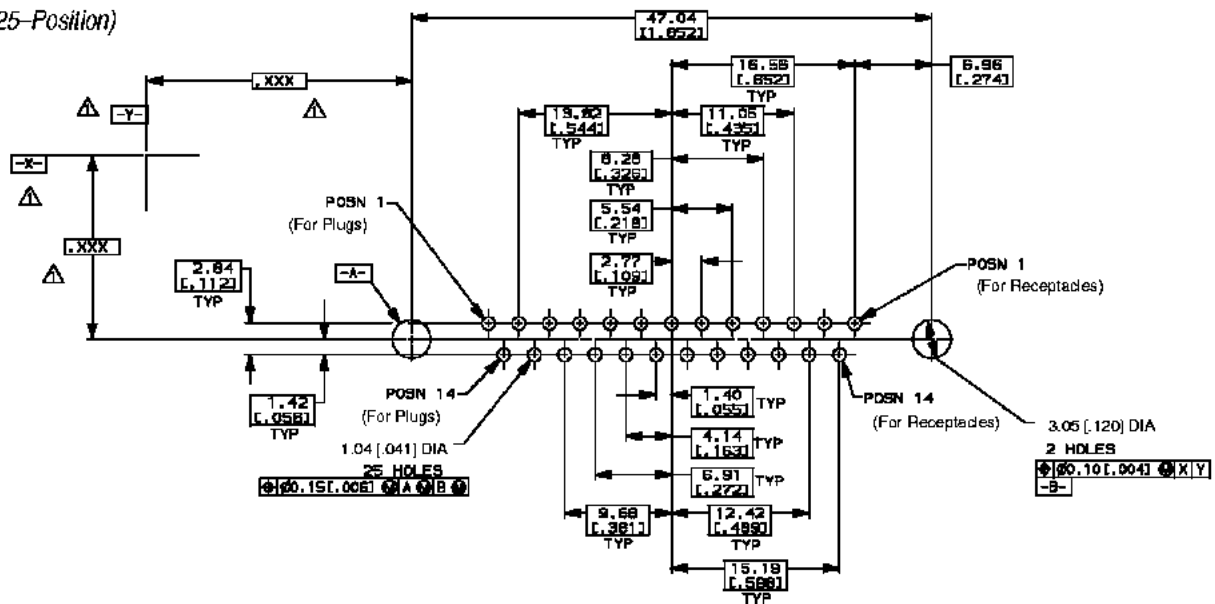
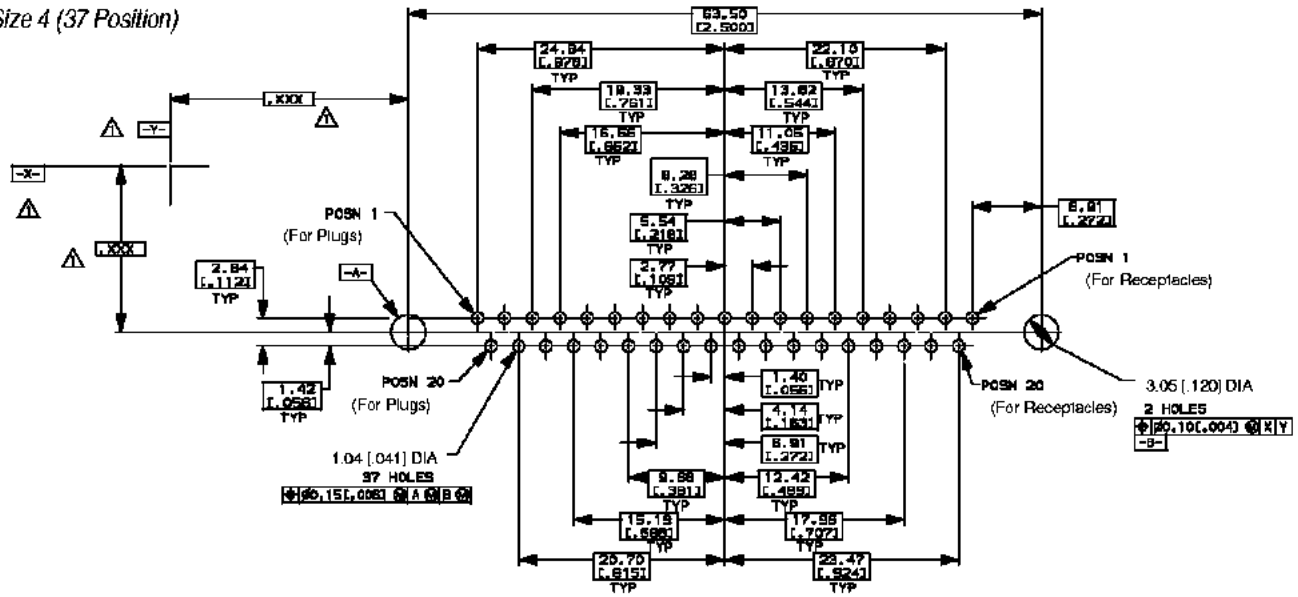
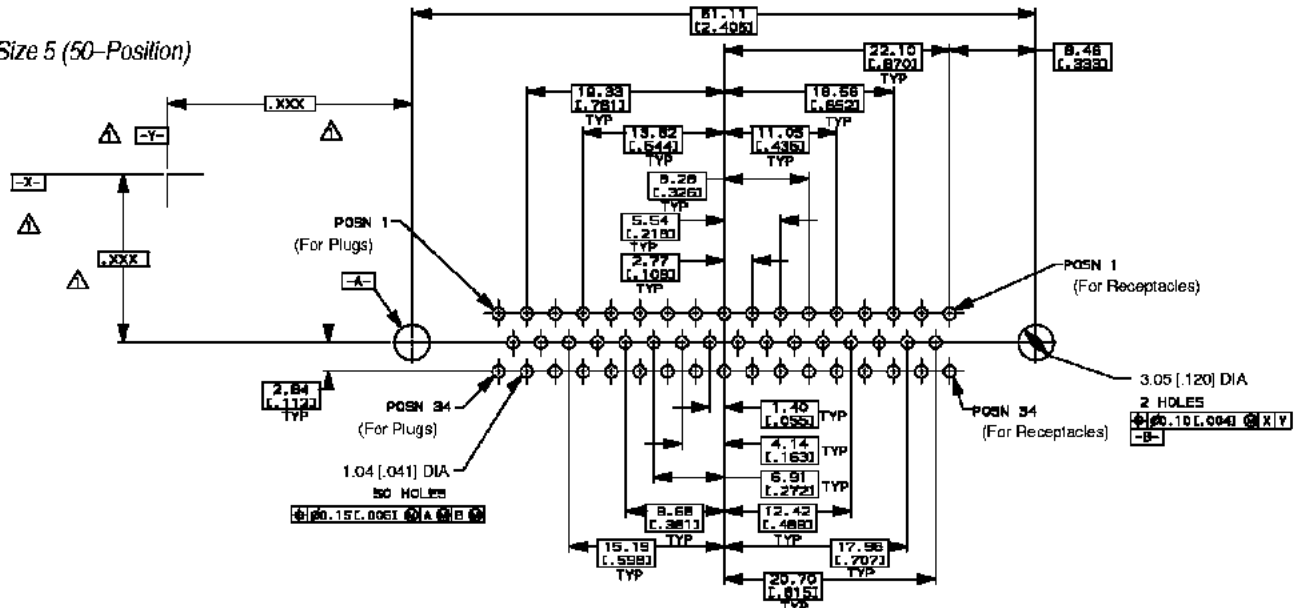

Figure 5 (cont'd)

Size 4 (37 Position)



Size 5 (50-Position)



△ Datums and basic dimensions established by customer.

**Datums A and B Mounting Hole Diameter:**

For Threaded Retention Inserts

After Drilling: 1.14 ±0.03 [0.045 ±0.001]

After Tin-Lead Plating: 0.94-1.09 [.037-.043]

After Reflow: 0.91-1.09 [.036-.043]

For Other Mounting Hardware

3.05 [0.120]

Figure 5 (end)

**3.5. Panel Mounting Cutout**

When panel mounting is required, AMP recommends that these connectors be mounted to the rear of the panel. Dimensions for proper placement in a panel are provided in Figure 6.

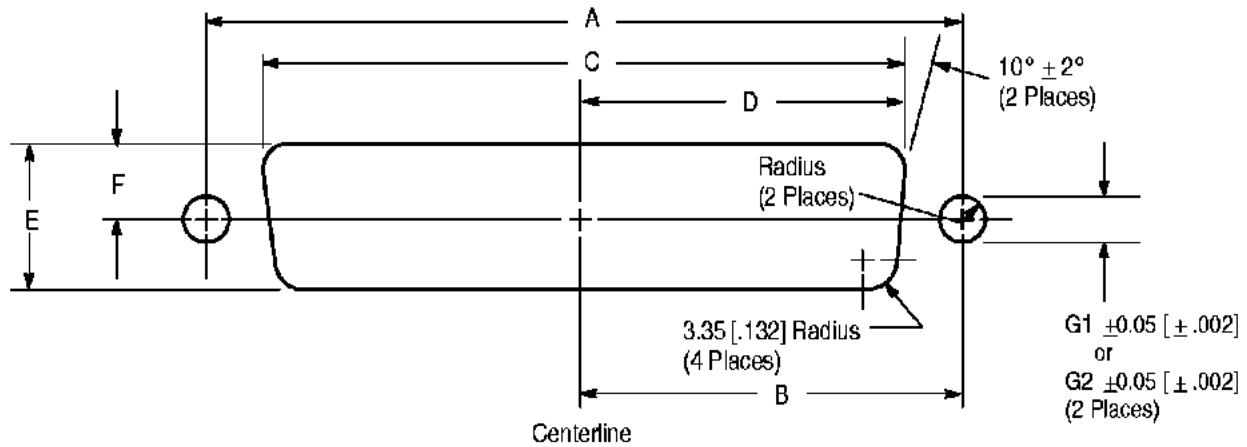

SHELL SIZE AND (NO. OF POSN)	DIMENSIONS							
	A	B	C	D	E	F	G1	G2
1 (9)	24.99 [0.984]	12.50 [0.492]	20.47 [0.806]	10.24 [0.403]	11.40 [0.449]	5.72 [0.225]	4.83 [0.190]	3.05 [0.120]
2 (15)	33.32 [1.312]	16.66 [0.656]	28.80 [1.134]	14.40 [0.567]				
3 (25)	47.04 [1.852]	23.52 [0.926]	42.52 [1.674]	21.26 [0.837]				
4 (37)	63.50 [2.500]	31.75 [1.250]	59.08 [2.326]	29.54 [1.163]				
5 (50)	61.11 [2.406]	30.56 [1.203]	56.34 [2.218]	28.17 [1.109]	14.10 [0.555]	7.06 [0.278]		

**NOTE:** Use the G1 dimensions for fixed female screwlocks and the G2 dimensions for all other types of hardware.

Figure 6

**3.6. Polarization and Keying**

The keystone configuration of the mating face prohibits the accidental inversion of mating connectors. To prevent mismatching connectors of the same size, keying plugs may be placed in the receptacle connector. The matching pin in the mating plug connector must be omitted. See Figure 7.

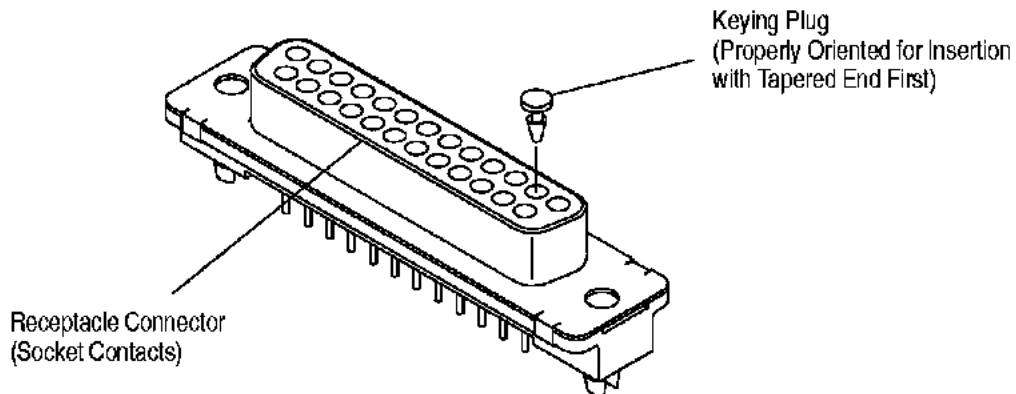

Figure 7

**3.7. Shielding**

The connectors feature tin-plated steel shells that provide electromagnetic compatibility (EMC). When mated with another metal shell connector, both shielding and grounding continuity are achieved. Use of metallic hardware provides additional reinforcement of electrical continuity.

**3.8. Mounting Hardware**

There are connectors with standard mounting holes which can be attached to the pc board with long female screwlock kits or commercially available hardware. Also, there are connectors with threaded retention inserts to be attached with short female screwlocks, and there are connectors with fixed female screwlocks. The recommended application for each type of hardware is shown in Figure 8.

**A. Connectors with Screwlocks**

Mounting hardware used to secure cable connectors to pc board connectors that have screwlocks must not exceed the torque value of 0.23 N•m [2 in-lb].

**B. Connectors with Threads in Flanges**

Mounting hardware used to secure connectors to pc board mounted connectors that have threaded inserts in the mounting flanges must not exceed the torque value of 0.45 N•m [4 in-lb].

**Connector with Standard Mounting Holes Using Removable Long Female Screwlock Kit**

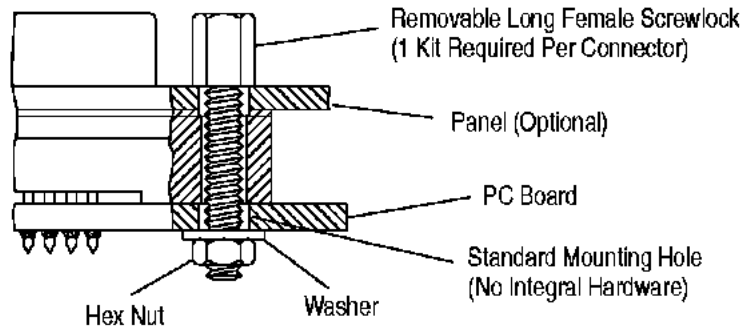

**Connector with 4-40 Fixed Female Screwlocks**

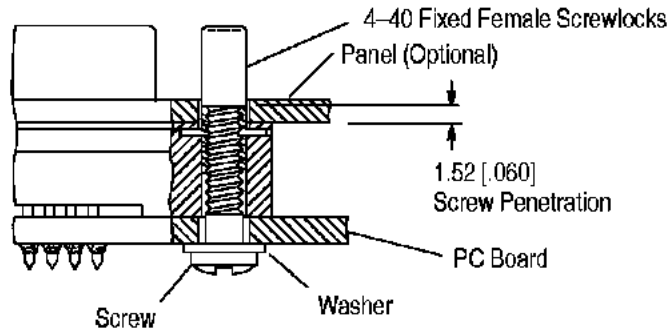

**Connector with 4-40 Threaded Retention Insert Using Removable Short Female Screwlocks**

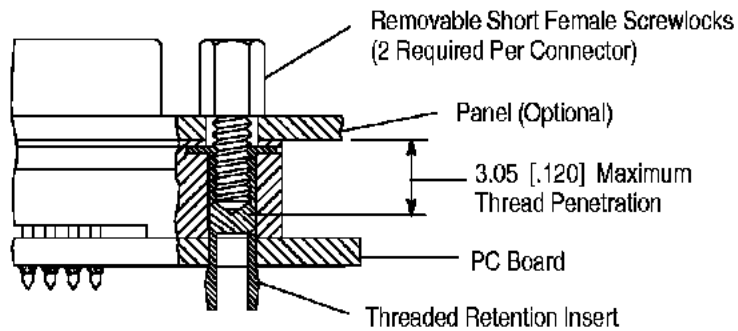

Figure 8

**3.9. Soldering**

**A. Flux Selection**

Contact solder tines must be fluxed prior to soldering with a mildly active, rosin base flux. Selection of the flux will depend on the type of pc board and other components mounted on the board. Additionally, the flux must be compatible with the wave solder line, manufacturing, health, and safety requirements. Call the Product Information phone number at the bottom of page 1 for consideration of other types of flux. Some fluxes that are compatible with these connectors are provided in Figure 9.

FLUX TYPE	ACTIVITY	RESIDUE	COMMERCIAL DESIGNATION	
			KESTER <sup>®</sup>	ALPHA <sup>■</sup>
Type RMA (Mildly Activated)	Mild	Noncorrosive	186	611

<sup>®</sup> Product of Kester Solder Co.    <sup>■</sup> Product of Alphametals Inc.

*Figure 9*

**B. Soldering Guidelines**

AMPLIMITE HD-20 Straight Contact Tine Connectors can be soldered using wave or equivalent soldering techniques. The temperatures and exposure time shall be within the ranges specified in Figure 10. We recommend using SN60 or SN62 solder for these connectors.

**NOTE** AMP Corporate Bulletin 401-52 provides some guidelines for establishing soldering practices.

SOLDERING PROCESS	TEMPERATURE		TIME (At Max Temp)
	CELSIUS	FAHRENHEIT	
WAVE SOLDERING	260 <sup>±</sup>	500 <sup>±</sup>	5 Seconds

<sup>±</sup> Wave Temperature

*Figure 10*

**C. Cleaning**

After soldering, removal of fluxes, residues, and activators is necessary. Consult with the supplier of the solder and flux for recommended cleaning solvents. The following is a listing of common cleaning solvents that will not affect the connectors for the time and temperature specified. See Figure 11.

Cleaners must be free of dissolved flux and other contaminants. We recommend cleaning with the pc board on its edge. If using an aqueous cleaner, we recommend standard equipment such as a soak-tank or an automatic in-line machine.

**DANGER** Consideration must be given to toxicity and other safety requirements recommended by the solvent manufacturer. Refer to the manufacturer's Material Safety Data Sheet (MSDS) for characteristics and handling of cleaners. Trichloroethylene and Methylene Chloride can be used with no harmful affect to the connectors; however AMP does not recommend them because of the harmful occupational and environmental effects. Both are carcinogenic (cancer-causing) and Trichloroethylene is harmful to the earth's ozone layer.

**NOTE** If you have a particular solvent that is not listed, contact the Tooling Assistance Center or Product Information number at the bottom of page 1.



CLEANER		TIME (Minutes)	TEMPERATURES (Maximum)	
NAME	TYPE		CELSIUS	FAHRENHEIT
Alpha 2110■	Aqueous	1	132	270
Bioact EC-7◆	Solvent	5	100	212
Butyl Carbitol●	Solvent	1	Room Ambient	
Isopropyl Alcohol	Solvent	5	100	212
Kester 5778■	Aqueous	5	100	212
Kester 5779■	Aqueous	5	100	212
Loncoterge 520●	Aqueous	5	100	212
Loncoterge 530●	Aqueous	5	100	212
Terpene Solvent	Solvent	5	100	212

■ Product of Fry's Metals, Inc.    ◆ Product of Petroferm, Inc.    ● Product of Union Carbide Corp.    ■ Product of Litlon Systems, Inc.

Figure 11

#### D. Drying

When drying cleaned connector assemblies, make certain that temperature limitations are not exceeded: -55° to 105°C [-67° to 221°F]. Excessive temperatures may cause housing degradation.

#### 3.10. Repair

Damaged connectors must be removed, discarded, and replaced.

#### 4. QUALIFICATIONS

AMPLIMITE HD-20 Connectors are Underwriters Laboratories Inc. (UL) recognized, File No. E28476 and Canadian Standards Association (CSA) certified, File No. LR7189.

#### 5. TOOLING

No tooling is required for the placement of these connectors onto the pc board.

**6. VISUAL AID**

Figure 9 shows a typical AMPLIMITE HD-20 Straight Solder Contact Tine, Front Metal Shell Receptacle Connector after it has been installed. The illustration is to be used by production personnel to visually ensure a suitable installation. Installations which appear visually incorrect should be dimensionally inspected using the information given in the preceding pages of this application specification.

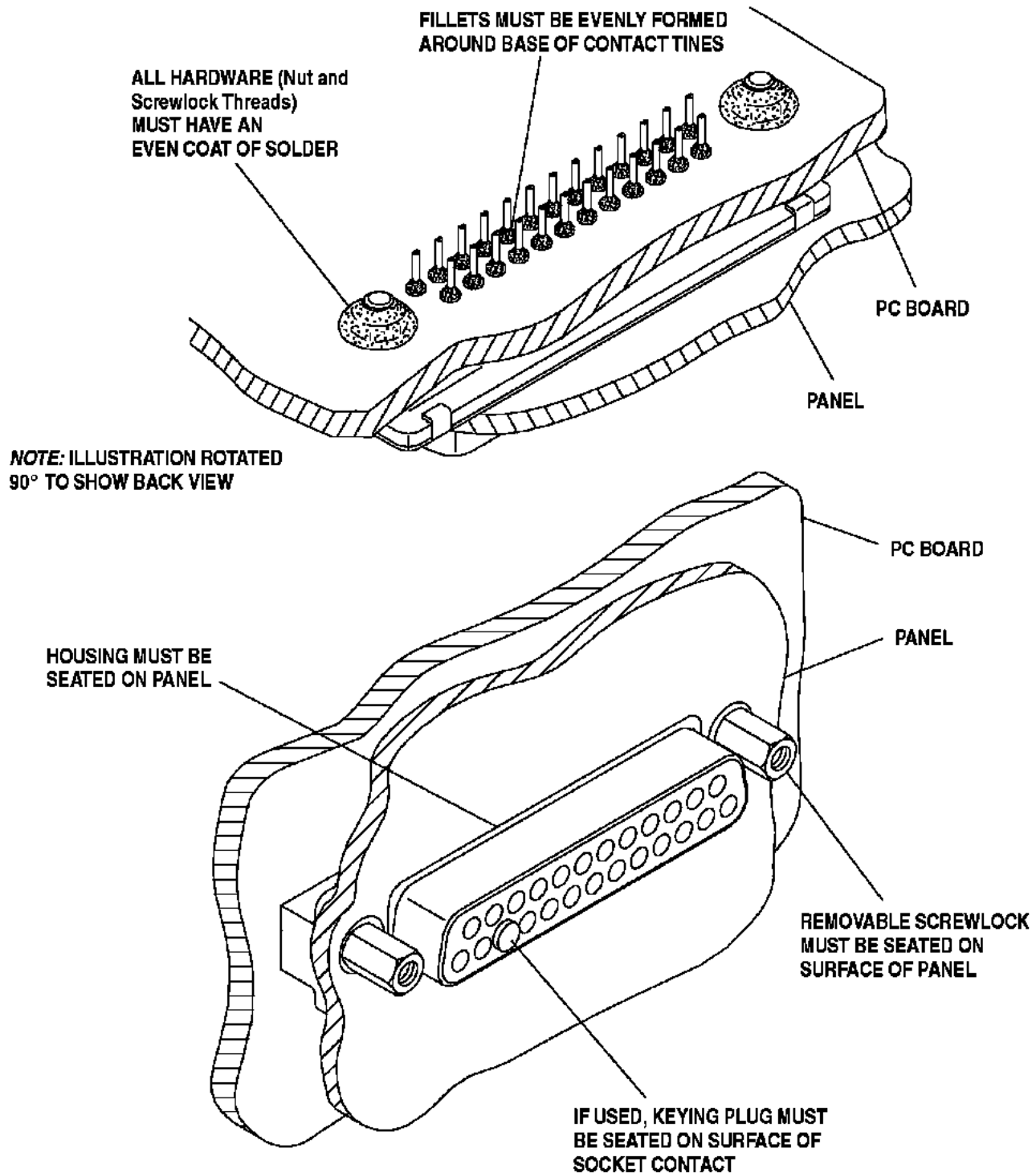
**FIGURE 12. VISUAL AID**